

SECTION: A-A

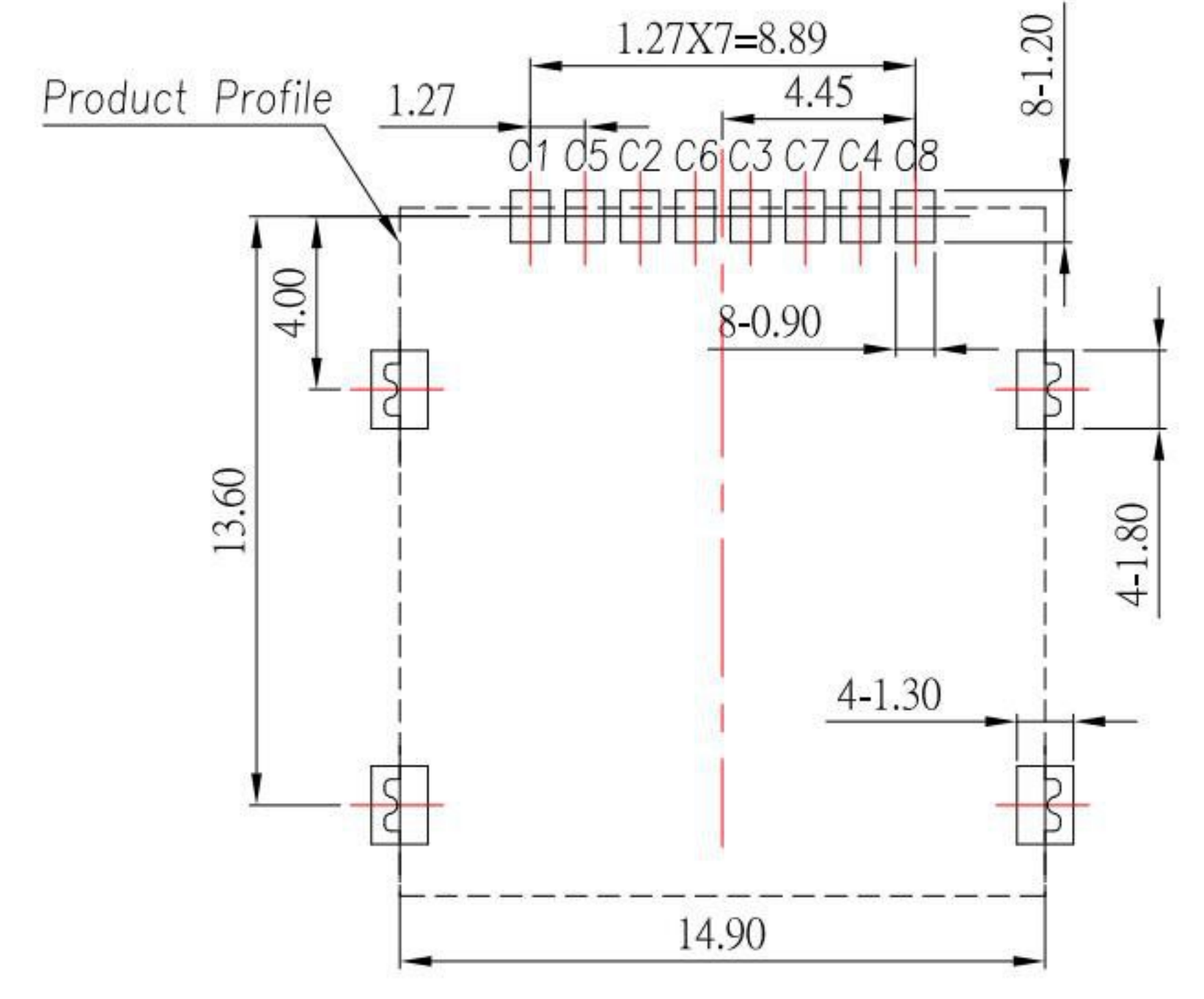

PCB LAYOYT

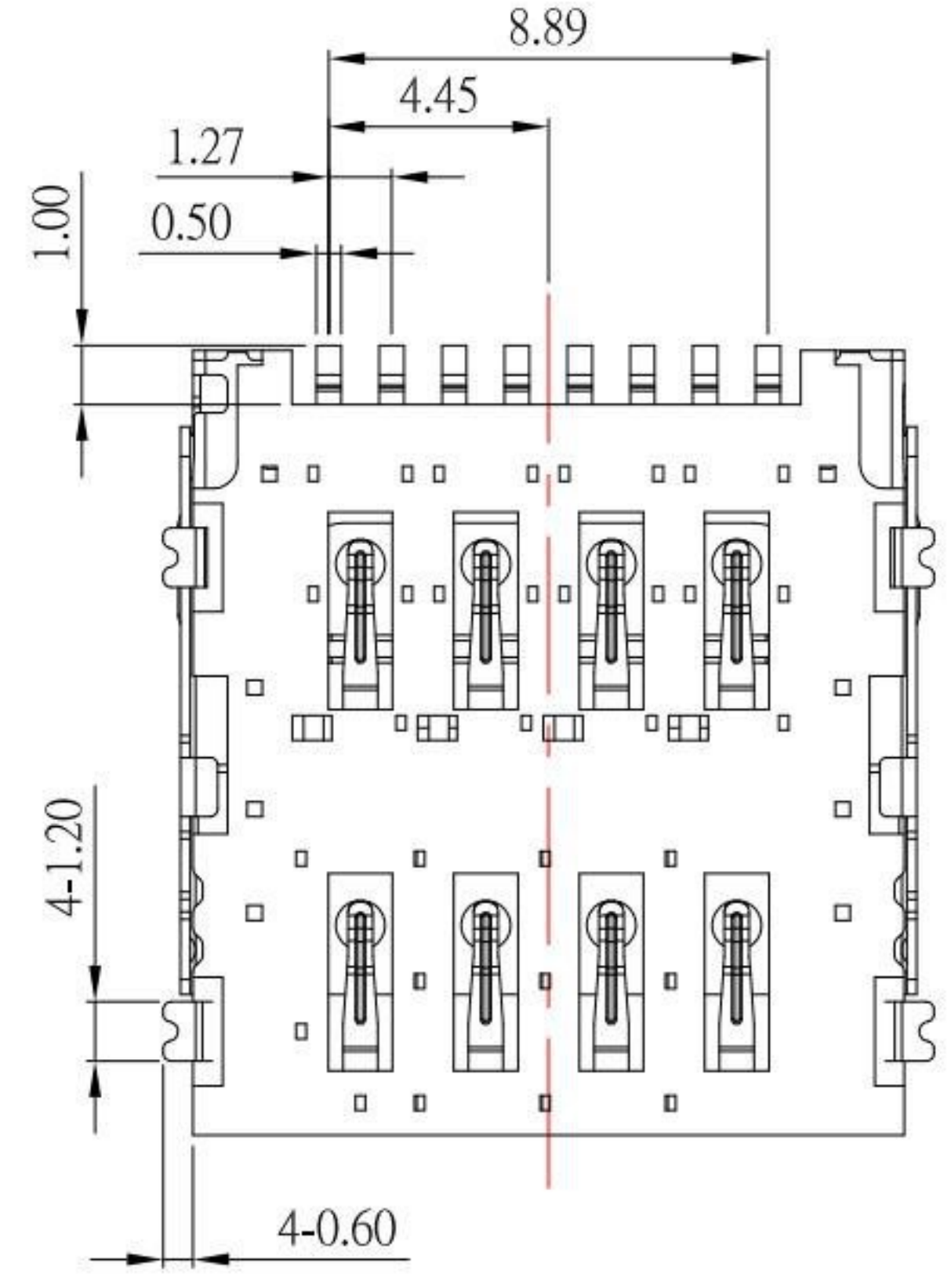
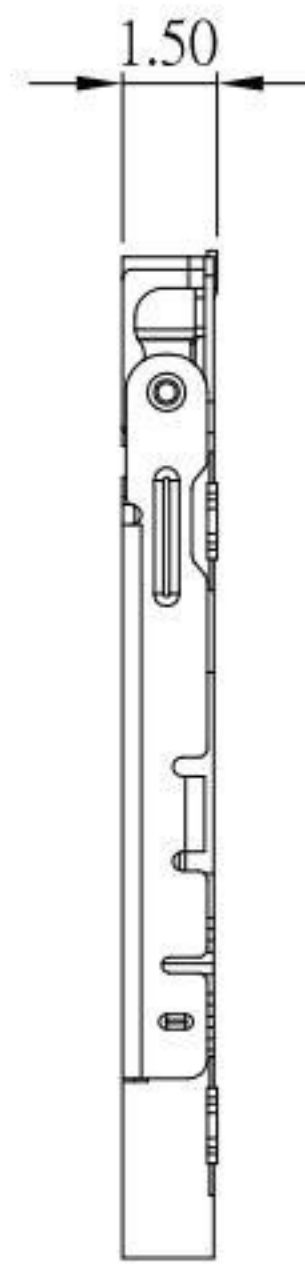
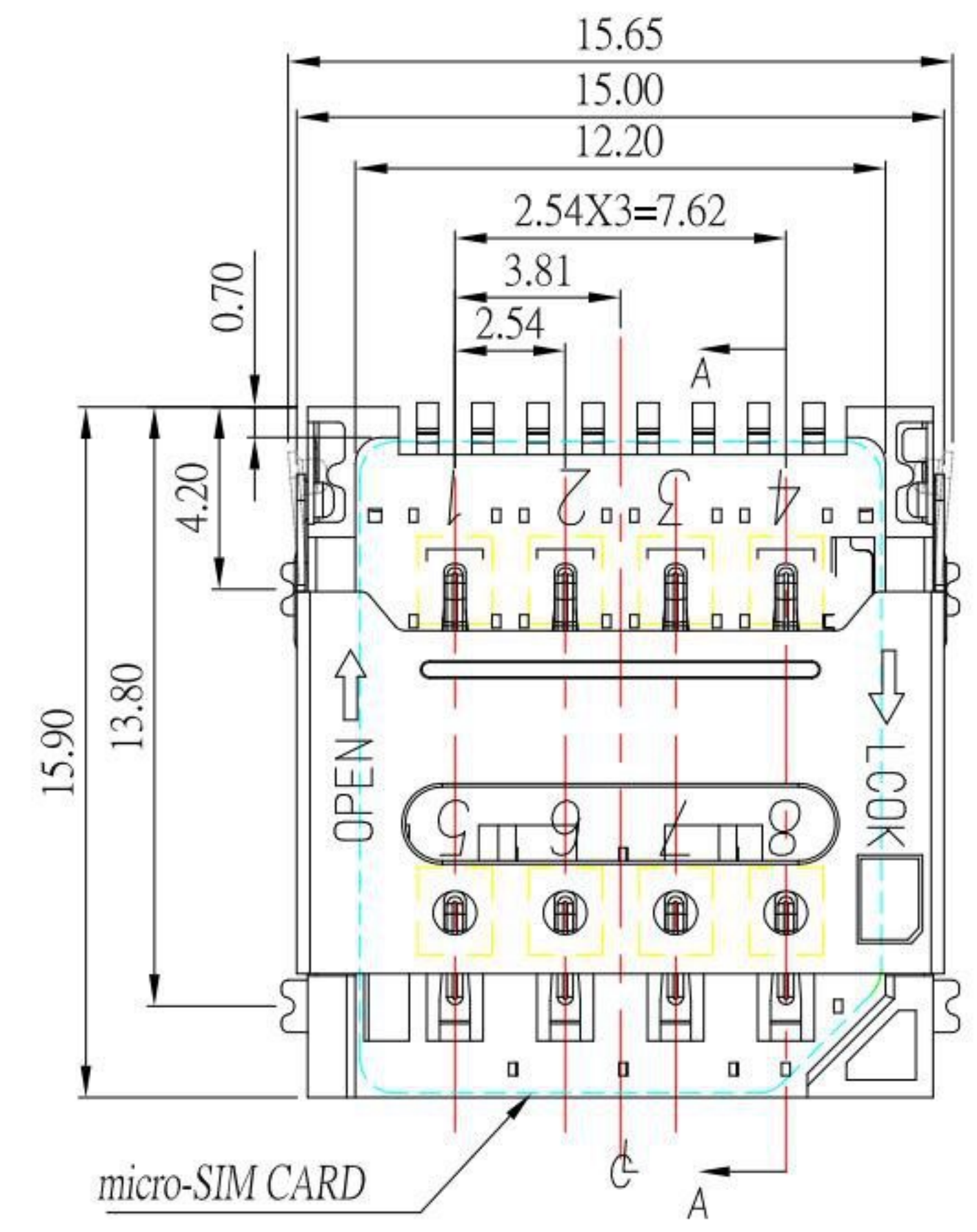
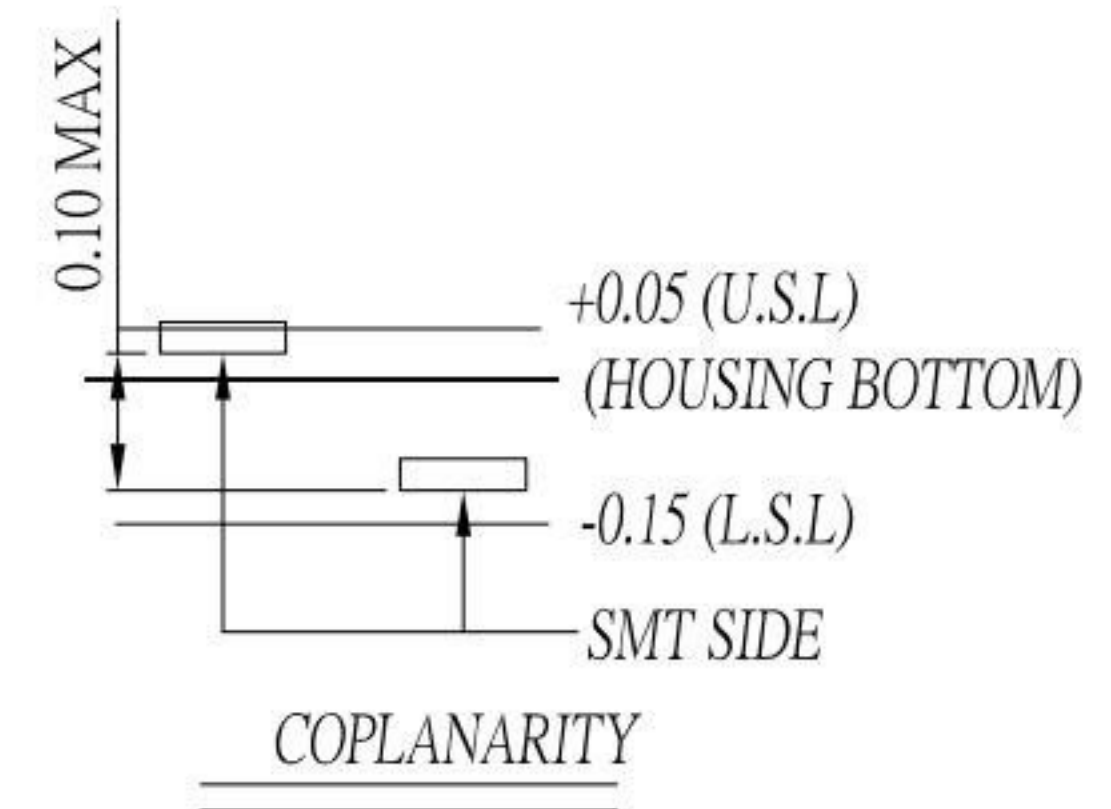
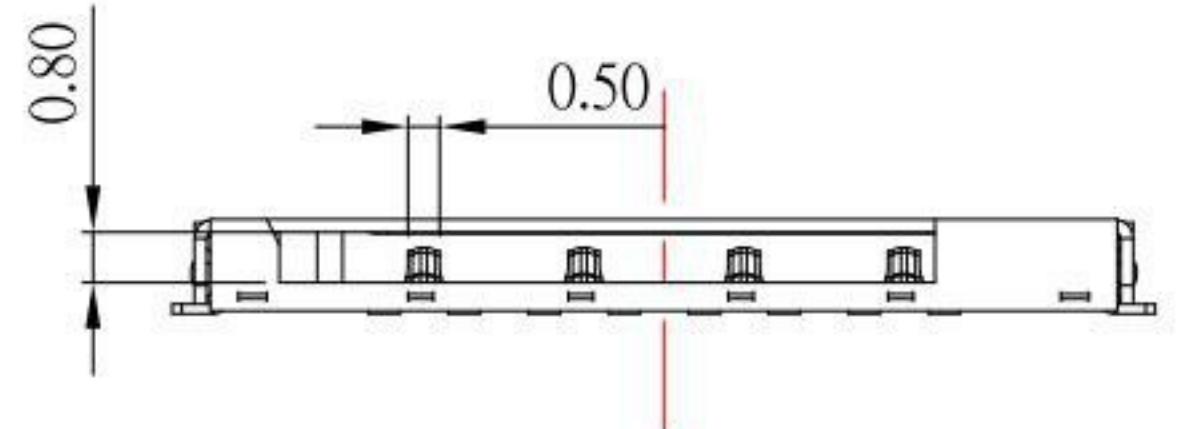

SIM CARD	
Pin No.	NAME
C1	VCC
C2	RST
C3	CLK
C4	RESERVED
C5	GND
C6	VPP
C7	I/O
C8	RESERVED

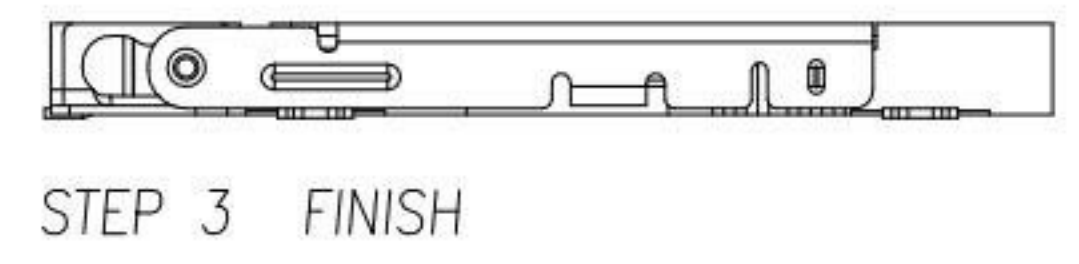
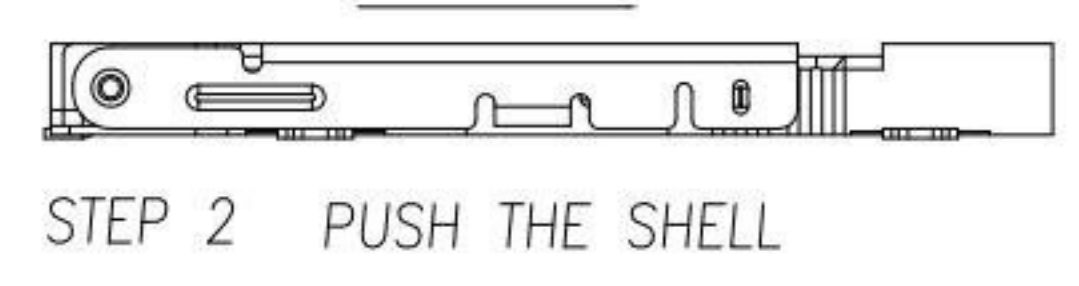
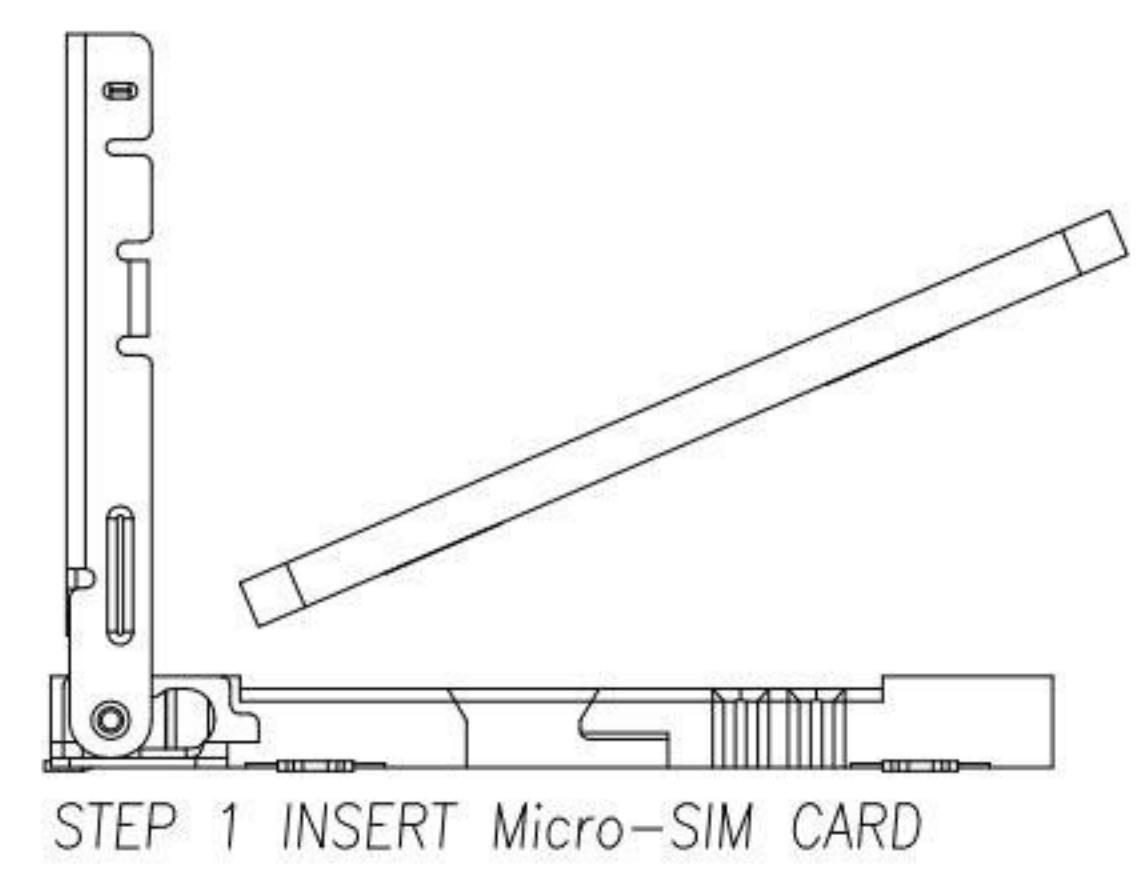

SPECIFICATION

- Electrical :
- Contact Resistance: 60 mΩ Max.
 - Insulation Resistance: 1,000 MΩ Min.
 - Dielectrec Withstanding Voltage: 500 V AC
- Material:
- Housing: Thermoplastic
 - Contact: Phosphor Bronze
 - Shell: SUS
- Finish:
- Contact: Plated Gold in Mating Area ;
Tin Plated on Solder Balls ;
Nickel under plated overall
 - Shell: Nickel under Plated surface laye

KSD 科斯达电子科技有限公司
 SWITCH CONNECTOR KSD ELECTRONIC TECHNOLOGY Co., LTD
 全球 互聯零组件制造企业

TOLERANCE UNLESS OTHERWISE STATED :	Up to 5 ±0.2	3RD. ANGEL'S	UNITS	MM
	Above 5 ~ 15 ±0.3			
	Above 15 ~ 30 ±0.4			
	Above 30 ~ 50 ±0.5			
	Angle ±0.3			

DRAWN BY:	DATE	MAT'L	TITLE	CONNECTOR
Jack Lu	03/22/18		MODLE	MICRO SIM 8PIN H1.5 掀蓋
CHECKED BY:	DATE	FINISH	DWG NO.	MSIM-08H150-S267
Jacky Chen	03/22/18		SCALE	1 : 1
APPROVED BY:	DATE	SHEET NO.	PART NO.	MSIM-08H150-S267
Tony Kao	03/22/18	1 of 1		

1	更新尺寸及更新為A0版	Jack	032218
ITEM NO.	DESCRIPTION	DRAWN	DATE